

AN ENGINEERING INSIGHT TO THE FUNDAMENTAL BEHAVIOUR OF TENSILE BOLTED JOINTS

Dr Saman Fernando
Ajax Technology Centre
76-88 Mills Road, Braeside Vic 3195

1. INTRODUCTION

The threaded fastener (nut and bolt) has played a significant role in the industrial revolution even though the exact date of its conception is not known. The concept of a helical thread was first introduced by Archimedes in the 3rd century B.C. Some archeologists argue that the threaded fastener was in existence even before Archimedes at the “Hanging Gardens of Babylon”. It is accepted that the common forms of threaded fastener assemblies have been in existence for at least 500 years. Threaded fasteners are probably the best choice to apply a desired clamp load to assemble a joint, at a low cost, with the option to disassemble if and when necessary. Furthermore, the simplicity of its mechanism of developing and maintaining the desired clamp force made it very popular and it has become one of the most accepted engineering products. In a negative sense, this simplicity may have made some users complacent and therefore to disregard some important issues associated with a bolted joint.

2. BOLTED JOINT

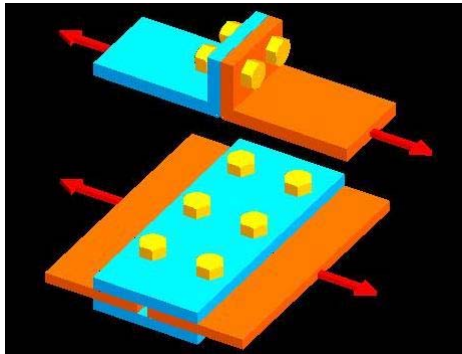

Based on the service loads there are two types bolted joints. In tensile joints the bolts are loaded parallel to the bolt axis while in shear joints the bolts are loaded predominantly perpendicular to the bolt axis. For example the connection of two flanges of a pressure vessel constitute a tensile joint while the connection of a beam to a column can be considered as a shear joint.

In a typical shear joint the bolt acts as a shear pin. The analysis of a shear joint is quite straightforward. The bolt does not need to maintain a specific tensile load. In this case the tensile load is applied only to prevent the nut from loosening. When the shear load on the joint

changes the corresponding stress field in the bolt also changes. Under dynamic loading this can lead to possible fatigue failure of the bolts.

Consider however that, a shear force can be transmitted with the help of friction forces perpendicular to the bolt axis, which are created by the tensile force on the bolt and friction between the plates/bolt/nut etc. Even though the joint supports a shear load, in this instance, it is considered as a tensile joint or more specifically as a friction joint. Essentially, for this joint the body of the bolt need not touch the joining members. In a friction joint a variation in the shear force does not cause a variation on the tensile force on the bolt. As a result for dynamic loading situations a friction joint will eliminate possible fatigue failure.

In most situations involving dynamic loading the tensile joint becomes a requirement and more attention is needed in the design of this joint. Therefore the rest of the discussion will be focussed on the tensile joint.

In order to shed some light on to the behaviour of a generic **tensile bolted joint** a comprehensive 3D Non-linear Elasto-Plastic Finite Element model analysis has been conducted. Results of this work will be published in the near future. Although most of the complexities of a generic tensile bolted joint can be addressed with the above comprehensive approach, cost and the effort requires does not qualify it as a generic engineering tool for wider applications. Therefore, an attempt has been made to develop a simple analytical method using fundamental theory and first order approximations. Although the approach presented here can be substantiated and calibrated by the aforementioned FEM analysis and experimental data, the emphasis made in this publication is to qualitatively highlight the importance of the various critical parameters associated with a generic tensile bolted joint.

The optimum pre-tension of a bolt in a joint has been a subject of confusion.

3. IMPORTANCE OF PRE-TENSION

In order to emphasize the importance of pre-tension or pre-load on the bolts in a bolted joint, the following first order analysis based on fundamental engineering principles is carried out. In a typical bolted joint one of the main functions of the bolt is to maintain an adequate positive clamping force during the service life of the joint in order to prevent leaks, relative movement, wear and fretting, etc. To achieve a particular service life requirement for a bolted joint it is very important to understand the effect of bolt pre-tension (F_i) and the applied load (F_a) on the Clamping force (F_c).

For simplified analysis purposes, two types of tension joint load configurations may be considered:

- An external load is applied at the surface adjacent to the nut and the head (Type A, Figure 1(a)),
- An external load is applied at the jointed interface (Type B, Figure 1(b)). These two types share the applied load differently between the fastener and the clamping force. However, in reality a typical joint will be a combination of the above Type A and Type B Joints.

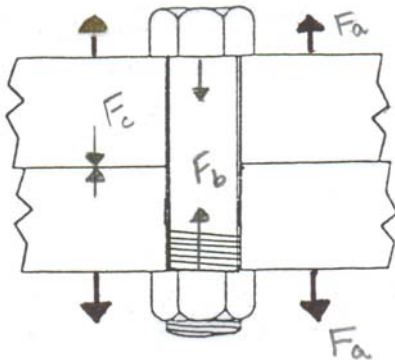

Figure 1(a): Type A Joint

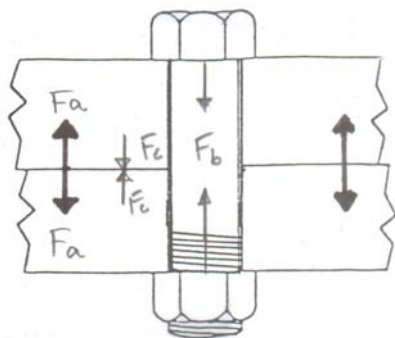

Figure 1(b): Type B Joint

Type A Joint:

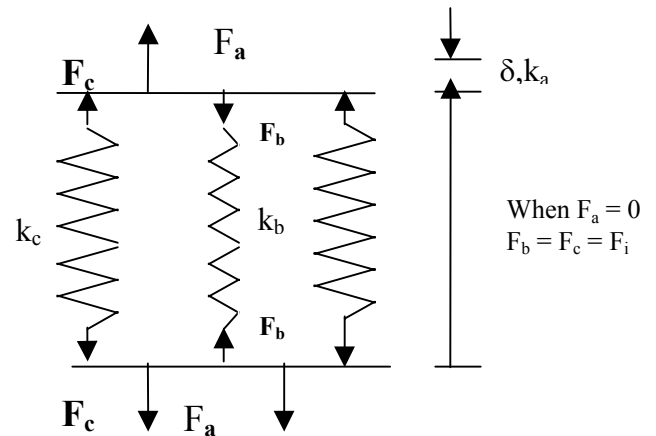

Figure 2: Mechanical representation of Type A joint

The bolt is represented by a tension spring of stiffness k_b while the joint is represented by a compression spring of stiffness k_c . With initial pre-load (F_i) and no external load applied, the spring system will be in equilibrium with,

$$F_b = F_i \quad (1)$$

$$F_c = F_i \quad (2)$$

where F_b is bolt tension and F_c is clamping force.

$$A_b \cong \frac{\pi}{4}(D^2) \quad (4)$$

$$k_b = \frac{A_b \cdot E_b}{L_b} \quad (3)$$

where A_b is the effective stress area of the bolt, E_b Young's modulus of bolt material and L_b the effective length of the bolt.

where D is the nominal diameter of the bolt.

$$k_c = \frac{A_c \cdot E_c}{L_c} \quad (5)$$

where A_c is the effective stress area of the joint members, E_c Young's modulus of joint material and L_c the effective length of the joint.

If $D_j < D_b$

$$A_c = \frac{\pi}{4}(D_j^2 - D_h^2) \quad (6)$$

where D_j the joint diameter, D_b bolt under head/washer bearing diameter and D_h the hole diameter.

If joint thickness $t < 8D$ and $D_b < D_j < 3D_b$,

$$A_c = \frac{\pi}{4}(D_b^2 - D_h^2) + \frac{\pi}{8} \left(\frac{D_j}{D_b} - 1 \right) \left(\frac{D_b L_g}{5} + \frac{L_g^2}{100} \right) \quad (7)$$

If $D_j > 3D_b$ then,

$$A_c = \frac{\pi}{4} \left[\left(D_b + \frac{L_g}{10} \right)^2 - D_h^2 \right] \quad (8)$$

where L_g is the grip length of the joint.

In general, due to the larger stress area ($A_c > A_b$), $k_c > k_b$ (Eqn (3), (5)). The applied force F_a will generate an overall displacement δ as shown in the Figure 2. This displacement imparts an additional load of $k_b \cdot \delta$ on the bolt.

The new bolt tension may now be represented by,

$$F_b = F_i + k_b \cdot \delta. \quad (9)$$

The same displacement relaxes the compression force on the joint members by $k_c \cdot \delta$ resulting a new clamping force of:

$$F_c = F_i - k_c \cdot \delta \quad (10)$$

For the equilibrium of forces:

$$F_a = \Delta F_b - \Delta F_c = k_b \cdot \delta + k_c \cdot \delta. \quad (11)$$

The resultant overall joint stiffness k_a can be defined as;

$$F_a = k_a \cdot \delta \quad (12)$$

By substituting (12) in (11);

$$\begin{aligned} k_a \cdot \delta &= k_b \cdot \delta + k_c \cdot \delta \\ k_a &= k_b + k_c \end{aligned} \quad (13)$$

Combining (12) and (13)

$$\delta = \frac{F_a}{k_a} = \frac{F_a}{(k_b + k_c)} \quad (14)$$

by substituting (14) in (9) and (10) respectively;

$$F_b = F_i + \frac{k_b \cdot F_a}{(k_b + k_c)} \quad (15)$$

$$F_c = F_i - \frac{k_c \cdot F_a}{(k_b + k_c)} \quad (16)$$

Equation (15) confirms that only a component of the applied load is contributing to increase the tension of the bolt. Typically k_c is larger than k_b and hence, the increase in the bolt tension will be less than the decrease in the clamping force. Therefore the parameter k_c/k_b has a significant impact on the performance of the joint.

The Figure 3 shows the relationship between F_i , F_b , F_c and F_a for bolted joint in the elastic range.

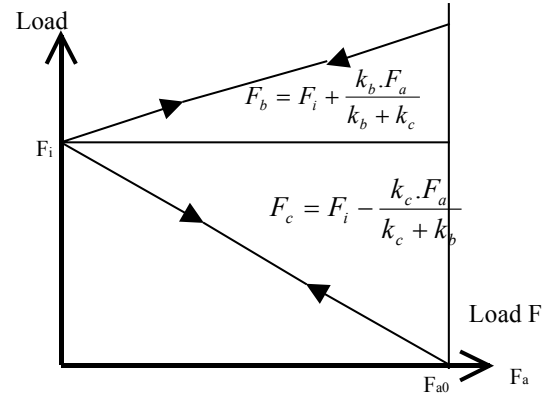

Figure 3: Variation of F_b and F_c with F_a in the Elastic region

From this graph it can be seen that $F_c = 0$ when

$$F_{a0} = \frac{(k_b + k_c) \cdot F_i}{k_c}. \quad (17)$$

This relationship proves that as high as possible pre-tension F_i will provide the best load carrying capacity for the joint. As discussed earlier, one of the main functions of a fastener is to keep the joint together. Therefore, it can be considered that the joint is failed when the applied load reaches F_{a0} .

The bolt tension when $F_c = 0$ is (combining (15), (16) and (17)),

$$F_{b0} = \frac{(k_b + k_c) \cdot F_i}{k_c} = F_{a0} \quad (18)$$

shall be smaller than the breaking load of the fastener.

For clamping load to become zero before the bolt reaches yield;

$$F_i < \frac{F_y \cdot k_c}{(k_b + k_c)} \quad (19)$$

where, F_y is the yield strength of the fastener.

In order to obtain a feel for the relative magnitudes of the above parameters the following example is given;

3.1 Example 1:

M20: Property Class 8.8 Bolt

(Property Class $X.Y$ is defined as Ultimate Tensile Strength $UTS = X * 100$ MPa and Proof Strength $YS = 0.1 * Y * UTS$)

| | | |
|----------------------------|-----------------|-----------------------|
| UTS | = 8 * 100 | = 800 MPa |
| YS | = 0.1 * 8 * 800 | = 640 MPa. |
| Effective Area | | = 245 mm ² |
| Proof Load | | = 147kN |
| Breaking Load | | = 203kN |
| Bearing Diameter (D_b) | | = 40mm |
| Effective Grip Length | | = 100mm |
| Young's Modulus | | = 200GPa |
| k_b (eq.(3)) | | = 245*200/100 kN/mm |
| | | = 490 kN/mm |

Joint:

| | |
|--------------------------|------------------------|
| Young's Modulus | =200GPa |
| Joint Diameter (D_j) | > 120mm |
| Hole Diameter (D_h) | =22mm |
| Length | =100mm |
| Effective Area (eq(8)) | =1583.5mm ² |
| k_c (eq.(5)) | =1583.5*200/100 kN/mm |
| | =3167kN/mm |

Note: In reality the bolt effective-length will be slightly larger than the joint effective-length. Joint effective area is based on using a high tensile washer on either end.

Now, $k_c/k_b = 3167/490 = 6.46$.

For most common applications this number is between 4 and 8.

Now maximum clamp load $F_{i\max}$ is (eq. (19));

$$F_{i\max} = \frac{F_y \cdot k_c}{(k_b + k_c)}$$

$$= 147 \frac{3167}{(490 + 3167)} = 127.3\text{kN}$$

This gives the *maximum pre-tension load* for this joint as $127.3/147*100\% = 86.6\%$ of the proof load.

The corresponding maximum applied load for the separation of the joint is (eq.(18));

$$F_{b0} = \frac{(k_b + k_c) \cdot F_i}{k_c} = F_{a0} = 147\text{kN},$$

i.e., the proof load of the fastener. This confirms that the tensile load applied on the joint at separation will be equal to the load on the fastener.

The Load vs Displacement graph for the above case is shown in Figure 4.

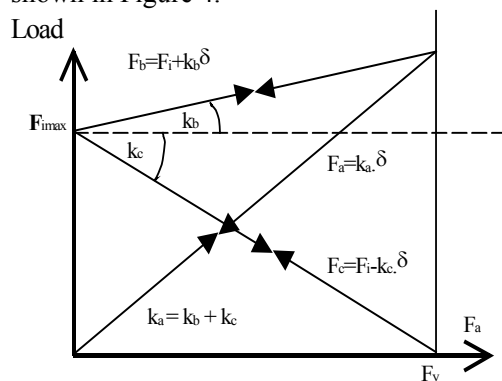

Figure 4: Load Displacement graph in the elastic zone.

Now, let's investigate what happens if the fastener was under tensioned. For example only 30% of the yield load, $F_{i2} = 0.3*147 = 44.1\text{kN}$.

The force at separation is (eq.(18));

$$F_{a02} = \frac{(k_b + k_c) \cdot F_{i2}}{k_c}$$

$$F_{a02} = (490+3167)*44.1/3167 = 50.9\text{kN}$$

This is a significant reduction from 147kN as calculated earlier. By reducing the pre-load from 127.3kN to 44.1kN (86.6% yield to 30% yield) the load carrying capacity of the joint has fallen from 147kN to 50.9kN. However, it is important to notice that the bolt will yield at a joint load of 48.9kN even though the joint has already failed by that time due to separation.

A graphical representation of the above process is shown in Figure 5.

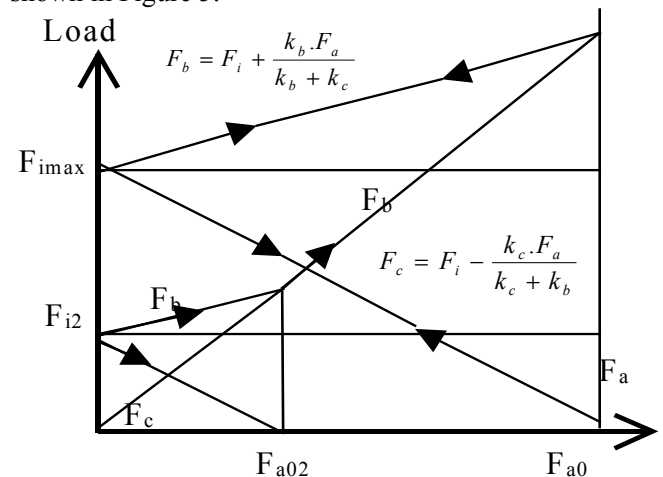

Figure 5: Effect of reduced pre-load.

As shown in Figure 5, when the pre-load is reduced from $F_{i\max}$ to F_{i2} the separation load is reduced from F_{a0} to F_{a02} . In this case, when the joint has failed the bolt is still far from its yield load. If the applied load is increased after separation of the joint, the total applied load will then be transferred to the bolt. The bolt load will increase at the same rate as the increase of applied load. As the joint is already separated, this will lead to further failure mechanisms such as bolt bending, fretting, joint wear, fracture etc. It is now clear that this is not the most economical way of using a bolt.

As discussed earlier, in eq. (15,16) the ratio k_c/k_b is an important parameter for a bolted joint. This determines the contribution of applied load to the bolt load. The larger this factor, the smaller is the effect on the bolt. This implies that the thinner and longer the bolts are better it is. However, it should be kept in mind that the load carrying capacity of a bolt is proportional to the square of the bolt diameter and therefore a reduction in diameter will have some negative effects. In general, a larger number of small diameter bolts are better than a small number of larger diameter bolts, especially under dynamic loading.

4. EFFECT OF DYNAMIC LOADING:

Most mechanical connections are subject to dynamic loads. Rotating and reciprocating machinery generates significant cyclic loads. One of the main failure modes associated with cyclic loading is fatigue. The fatigue life of a bolt can be estimated by a combination of S-N and S'_a vs S_m diagrams, where S'_a is the fluctuating stress, S_m is mean stress and N is number of cycles for failure. This theory is well established and reported elsewhere. A simple example is presented here in order to highlight the importance of pre-load on the fatigue life of a bolted joint.

Figure 6 shows the effect of the peak fluctuating stress (S'_a) on the lifetime of the product when subject to a regular cyclic load. The lifetime is given as the number of cycles that the product can undergo before fatigue failure. As we decrease the magnitude of the fluctuating stress, in this case less than 421MPa, the life time will approach infinity as it will not subject to fatigue failure. Similarly, if we increase the peak alternating stress the lifetime will decrease. In this example, as the peak alternating stress approaches 772MPa, failure will occur around 10^3 cycles.

In general, wind and earthquake dynamic loads will have irregular frequency and amplitudes. Although the same theory stated here can be used to estimate the fatigue life the treatment would be somewhat complicated.

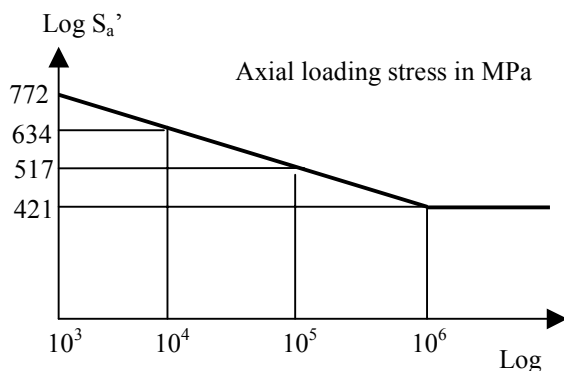

Figure 6: Peak alternating stress S'_a vs Life N cycles graph (S-N Curve) for Class 10.9 Steel

Figure 7 shows the effect of peak alternating stress and the mean tensile stress on fatigue failure. As can be expected, when the mean stress reaches ultimate strength (S_u), the sample will fail without any fluctuating load. On the other hand, when the peak alternating stress is 772 MPa and mean stress is zero, it will fail around 10^3 cycles. The effect of combining alternating and mean stresses on fatigue life is shown in Figure 7.

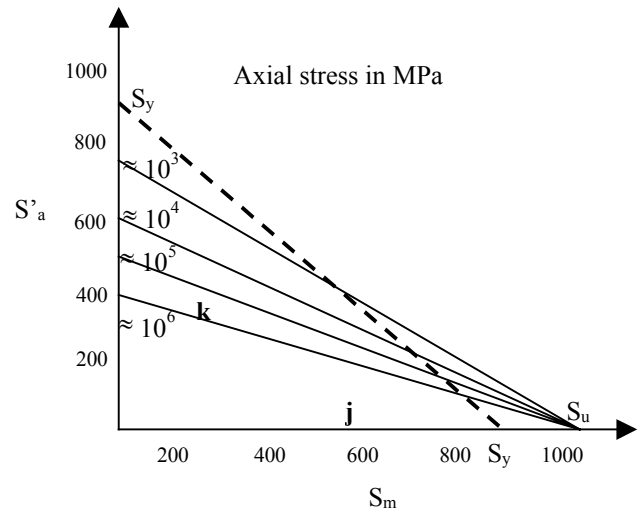

Figure 7: S'_a vs S_m curve for class 10.9 steel.

To understand the effect of pre-load on fatigue life, the following example is considered:

4.1 Example 2:

Bolt: M20, Class 10.9, eff. grip length 100mm
 $S_u = 1000\text{MPa}$ $k_b = 168\text{kN/mm}$
 $S_y = 900\text{MPa}$ $k_c = 1050\text{ kN/mm}$
 $F_y = 203\text{kN}$ $F_a = 58\text{ kN (mean)}$
 $F_u = 255\text{kN}$ $F'_a = 81.2\text{kN (peak alternating)}$

Case 1:

Pre-Load = $F_i = 60\% F_y = 121.8\text{ kN}$

$$F_b = F_i + \frac{k_b \cdot F_a}{(k_b + k_c)}$$

$$F_b \text{ (mean)} = 121.8 + 490 \cdot 58 / (3167 + 490) = 129.6\text{ kN}$$

$$= 100 \cdot 129.6 / 203 \% F_y$$

$$= 63.8\% F_y$$

$$S_m = 0.638 \cdot 900 = 574\text{MPa}$$

$$F_{a0} = \frac{(k_b + k_c) \cdot F_i}{k_c}$$

$$F_{a0} = (490 + 3167) \cdot 121.8 / 3167 = 140.6\text{ kN}$$

$$F'_b = 81.2 \cdot 490 / (490 + 3167) = 10.9\text{ kN} = 5.4\% F_y$$

$$S'_a = 0.054 \cdot 900 = 48.6\text{ MPa}$$

Case 2:

Pre-Load = $F_i = 25\% F_y = 0.25 \cdot 203 = 50.75\text{ kN}$

$$F_b = F_i + \frac{k_b \cdot F_a}{(k_b + k_c)}$$

$$F_b (\text{mean}) = 50.75 + 490 \cdot 58 / (3167 + 490) = 58.5 \text{ kN} = 28.8\% F_y$$

$$S_m = 0.288 \cdot 900 = 259 \text{ MPa}$$

$$F_{a0} = \frac{(k_b + k_c) \cdot F_i}{k_c}$$

$$F_{a0} = (490 + 3167) \cdot 50.75 / 3167 = 58.6 \text{ kN}$$

$$F'_b = (58 + 81.2 - 58.6) + 58.6 - 58.5 = 80.7 \text{ kN} = 39.75\% F_y$$

$$S'_a = 0.3975 \cdot 900 = 357.75 \text{ MPa}$$

The above parameters for Case 1 and Case 2 are shown in Figure 8. For Case 1, a pre-load of 60% F_y is applied. The mean applied load of 58 kN result in a mean bolt load of 129.6 kN. An applied load of 140.6 kN will separate the joint.

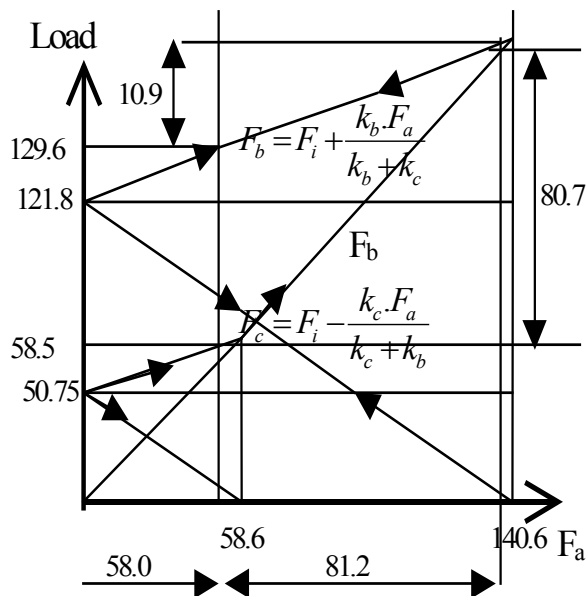

Figure 8: Loading diagram for example 2.

The peak fluctuating component of the 81.2 kN applied load imparts a fluctuating bolt load of 10.9 kN. As the total maximum applied load (58+81.2=139.2 kN) is less than 140.6 kN the joint will not separate under applied load conditions. The mean (S_m) and peak fluctuating stress (S'_a) for Case 1 are 574 MPa and 48.6 MPa respectively. This point is shown as point ① in Figure 7 and is in the area where no fatigue failure will occur.

In Case 2, the pre-load is only 25% F_y = 50.75 kN. This may be a result of tightening error of the bolt. As a result the clamp separation load is reduced to only 58.6 kN. That means when the joint load of 58+81.2 kN is applied, the joint will separate (this may be considered as failure) and the load excess of 58.6 kN will be transmitted directly to the bolt. Under the mean load of 58 kN, the bolt will experience a mean load of 58.5 kN resulting a mean stress S_m of 259 MPa. The fluctuating load of 81.2 kN imparts a fluctuating bolt load of 80.7 kN resulting a peak fluctuating stress S'_a of 357.3 MPa. This point is shown as ② in Figure 7. This

point is clearly within the life span of 10^6 cycles limit. This implies that the bolt will fail around 10^6 cycles.

This example clearly identifies importance of properly tightening the bolts in dynamic situations. Reduction of pre-load from 60% Yield to 25% Yield will alter the joint from no fatigue failure to fatigue failure.

A similar problem may occur if the bolts are over tightened. The following example shows the effect of over-tightening the bolts.

Case 3:

If the initial pre-load is set up at 95% of the yield load (F_i = 192.9 kN) in Case 1 of the previous example, the bolt load at mean applied load (58 kN) is;

$$F_b = 192.9 + 490 \cdot 58 / (3167 + 490) = 200.7 \text{ kN}$$

When the fluctuating component of 81.2 kN is applied as shown in Case 1, this will impart a fluctuating load of 10.9 kN on the bolt. Now the total applied load of 211.8 kN (200.7 + 10.9) will exceed the yield load (203 kN) of the bolt and will be subject to plastic deformation. When the fluctuating component is released momentarily the pre-tension of the bolt is lost due to plastic deformation. The loss of pre-tension makes it similar to Case 2 and leads to failure by both joint separation and fatigue.

Therefore it is crucial that the bolt pre-tension has to be within a very specific range to achieve correct and optimum performance of the joint.

5. TORQUE TENSION RELATIONSHIP:

Now that the importance of the bolt pre-tension is established it is important to investigate how this can be reliably achieved.

Torque has been considered synonymous with tension in the past with the unavailability of an economical and reliable bolt tensioning method. Several approximations has been used in the design of bolted joints at varying success and confident level in order to relate the torque to tension.

The Nut Factor approach is the most commonly used. The simplified torque tension relationship;

$$T = K \cdot D \cdot F$$

where K – Nut Factor, D – Bolt Diameter and F is the Bolt Tension.

This formula can be further expanded to;

$$T = F \cdot D \cdot (K_1 + K_2 + K_3).$$

where K_1 , K_2 and K_3 are contributions due to bolt stretch, thread friction and under-head/under-nut bearing friction respectively. The following chart describes these parameters.

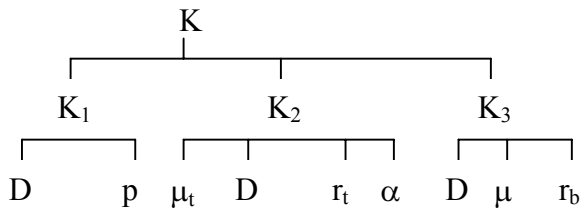

Using energy balance principals a first order relationship between the torque (T) and Tension (F) can be derived as follows;

In a rotation of the nut by $\delta\theta$;
 work done by torque = $T \cdot \delta\theta$
 work done by tension = $F \cdot p \delta\theta / 2\pi$
 work done by thread friction = $F r_t \mu_t \delta\theta / \cos\alpha$
 work done by under head friction = $F \cdot r_b \cdot \mu_b \delta\theta$

where, p thread pitch, α thread flank angle, r_t effective thread radius, r_b effective bearing radius, and μ_t and μ_b are thread and bearing friction coefficients respectively.

Now for energy balance;

$$T \delta\theta = \frac{Fp}{2\pi} \delta\theta + F \frac{r_t \mu_t}{\cos\alpha} \delta\theta + F r_b \mu_b \delta\theta$$

$$T = F \cdot D \cdot \left[\frac{p}{2\pi D} + \frac{r_t \mu_t}{D \cos\alpha} + \frac{r_b \mu_b}{D} \right]$$

$$T = F \cdot D \cdot (K_1 + K_2 + K_3)$$

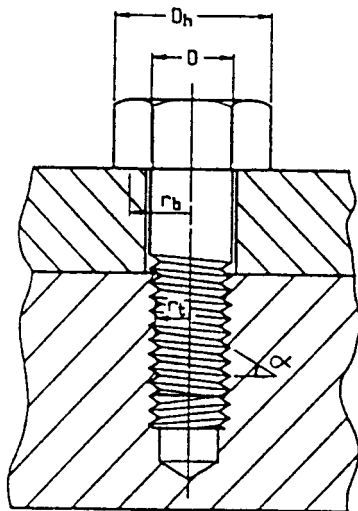

$$K_1 = \frac{p}{2\pi D} \cdot K_2 = \frac{\mu_t r_t}{D \cos\alpha} \cdot K_3 = \frac{\mu_b r_b}{D}$$

Figure 9: Parameters associated with Torque-Tension Relationship.

Term $K_1 D$ represent the contribution of the torque towards bolt elongation and joint compression, $K_2 D$ the fraction of torque spent on overcoming thread friction and $K_3 D$ the fraction of torque spent on overcoming under head friction.

For a M12 bolt;
 Pitch p = 1.75mm
 Thread friction μ_t = 0.15
 Thread radius r_t = 6mm
 Thread angle α = 30°
 Under head friction μ_b = 0.15
 Effective under head radius = 8mm

Now;
 $T = F (0.28+1.04+1.2)$
 $K_1:K_2:K_3 = 0.28:1.04:1.2 = 11:41:48 \%$

From this simple analysis it is evident that typically, around 10% of the effort is going to the stretch of the bolt and compression of the joint, 40% of effort is going to overcome thread friction and the remaining 50% is going to overcome bearing friction. This implies that approximately 90% effort is going to overcome friction while only 10% is doing useful work.

There are a large number of parameters such as, surface finish, hardness, lubricants, among other things, that can alter the friction coefficients associated with a bolted joint. A 10% reduction in friction contribution (from 90% - 81%) will increase the bolt stretch-joint compression contribution from 10% - 19% which is a 90% increase.

As such, it shall be understood that the torque tension relationship is not a reliable way of ensuring the tension of the bolt under most situations. The value of K can vary from approximately 0.2 to 2.0 depending on the condition of the bolt and the bolted joint.

Any irregularity or damage to the thread can also be seen as an increased friction hence adding to the overall variability of the friction coefficient. Therefore, if the torque is used as a measure of tension it shall be made sure that the thread is in perfect shape. Galling of threads can also contribute to significantly large friction forces.

Torque tension scatter varies largely with the size of the bolt, coatings, interface friction, and joint geometry. With large bolts (>M30) this scatter may be as high as 300%.

Figure 10 shows the torque vs tension relationship measured for M8, property class 8.8, Zinc electro plated bolts and nuts (without any lubricant) tightened on the same joint. Each bolt assembly is used only once. The solid line shows the theoretical relationship between tension and torque assuming typical friction values for Zn coated interfacing surfaces. The spread between the six samples are quite significant. The recommended assembly torque for the above bolts is 15.4Nm to achieve a tension of 13.8kN which is 65% of the proof load. At 15.4 Nm torque the six samples

achieved tension values from 11 to 17 kN. The spread of 6kN is a 43% variation on the desired tension value. If a 90% of the proof load was desired (19.1kN) the torque values from 17.5Nm to 33Nm were required to achieve the desired tension on different bolts. If a 33Nm torque is applied to each bolt, that would have failed several of the above bolts!!!

13kN were achieved depending on how many times the bolt was tightened. Again the spread on the desired tension is over 50%. The above figures are typical for all bolt sizes, however, the large bolts will have greater variations in the torque tension relationship.

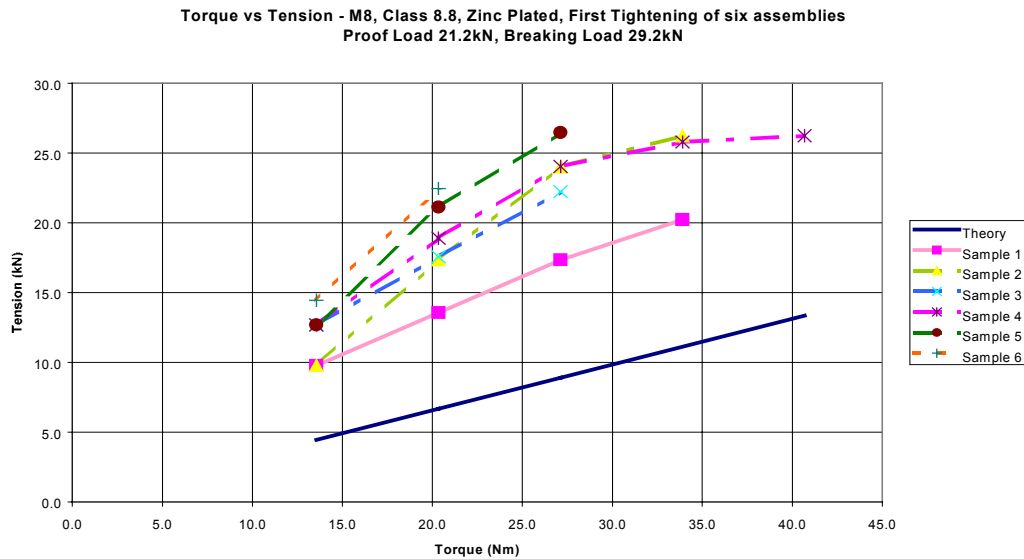

Figure 10: Torque Tension Relationship; M8, Class 8.8, Zinc plated bolts, first tightening six samples. As plated, no lubrication. Proof Load 21.2kN, Breaking Load 29.2kN.

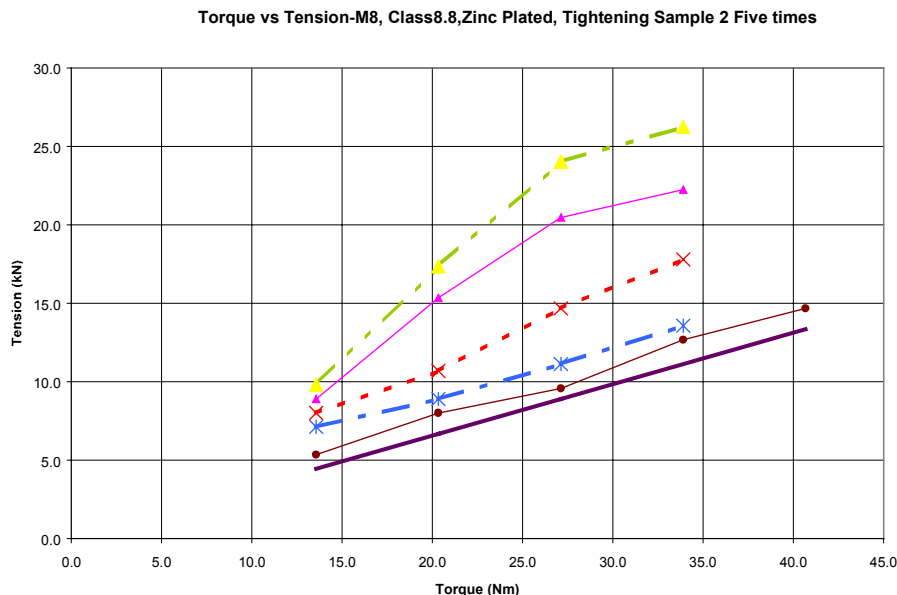

Figure 11: Repeated tightening of the above Sample 2 for five times.

Figure 11 shows the first and subsequent four tightening of the Sample 2 bolt in the above experiment. For a tightening torque of 15.4Nm, tension values from 6 to

6. CONVENTIONAL METHODS OF TIGHTENING

Although, most of the practitioners understand the importance of bolt tension in a bolted joint the conventional tightening methods only provide a vague indication of the bolt tension. Extensive research carried out on torque-tension relationships prove that under most uncontrolled situations using torque as a measure of tension can lead to a error as large as $\pm 50\%$. Even under controlled conditions torque on its own is not a reliable measure of tension. On the other hand, the reliable tension measuring systems are cumbersome and expensive. A comparison of various methods available for achieving pre-load in terms of their reliability and relative cost are shown in Figure 12.



Figure 12: Comparison of common tightening methods

Another commonly used method is the “turn of the nut” method. This method, in fact, is the recommended method by Australian Steel Codes AS4100. In this method the nut is tightened to a “snug tight” position and then tighten further fraction of a turn depending on the joint geometry. However, the standard does not specifically define the “snug tight” position. According to the theory, the “snug tight” position is where a step change in the gradient of the torque vs angle curve occurs. In order to carry out this process with any accuracy a torque sensor and an angle encoder shall be used. Then by calibrating on the desired joint with a direct tension measuring device the required nut rotation after the snug tight position can be determined. This will then provide a method of tightening with some degree of accuracy. However, for example, for tightening slew-ring bolts this method may not be suitable. Snug tight position for one bolt may change

with the tightening of the remaining bolts hence making this method not reliable at all.

Load Indicating Washer (LIW) is another common method of assuring desired tension. Again this method will not give satisfactory results for tightening slew-ring bolts as the firstly tightened bolts will become loosen when tightening the subsequent bolts. LIWs are capable of indicating the tension only in their first tightening.

Hydraulic Bolt Tensioning is relatively popular in heavy industries due to its simplicity. However, when using this method, the bolt tension is known only when the hydraulic pressure is applied (by measuring the hydraulic pressure). Once the hydraulic pressure is removed and the load is transferred from the jack to the nut, bolt and the tightening flanges, the applied tension on the bolt is relaxed. In one experiment carried out by ATC on a large rock crusher showed

that at a 8bar hydraulic pressure applied on three M64 Flange bolts resulted in a 80 -90% of proof load initially and then relaxed to 45 – 56% proof load once the pressure is removed. It was found that the relaxation is a function of bolt/nut size, number of threads engaged, and the flange dimensions among other parameters. However, it was not possible to establish a firm relationship with the applied hydraulic pressure and the final bolt tension.

Heating the bolts at tightening is another method of obtaining a pre-load. The bolt is heated to a known temperature with the help of a concentrated heat source. This will elongate the bolt. The nut is tightened at this point and let the joint to cool down. The shrinkage of the bolt will impart a pre-tension on the joint. This method is not very advisable for tightening high tensile bolts as the tensile strength of the bolt may be significantly affected by heating the bolt. Control of the bolt temperature is extremely difficult and large variations in temperature may be

observed over the bolt. This may result in variable material properties over the bolt.

Another factor that affects the bolt tension is the joint temperature. Especially if the joint is made of dissimilar materials, the differential thermal expansion of the bolt and joint materials will cause variations in the bolt tension. Even if the bolts are tightened accurately to the desired tension value, if the joint is subject to temperature variations the working tension on the bolt may change. It is not possible to theoretically estimate these changes to a sufficient accuracy. Only direct tension measurement will provide the engineer with the real time working tensions on such bolts.

7. LOADING BEYOND YIELD

In most situations the pre-tension load will be less than the yield load, however, due to the applied loads the bolt exceeds yield load. The work hardening materials generally exhibit elastic-plastic behavior. For simplicity, perfectly linear-elastic and perfectly linear plastic behavior of the bolt material is assumed. The typical stress strain relationship for such material is shown in Figure 13. The gradient of the elastic zone is the Young's Modulus (E) and the gradient of the plastic zone is the plastic modulus (E_p). For all elastic plastic materials $E_p < E$. Once the material reaches plastic stage when the applied load is removed the material will not return to its original shape. The plastic deformation is as shown in the Figure 13.

Based on the previous analysis therefore, $k_{bp} < k_b < k_c$.

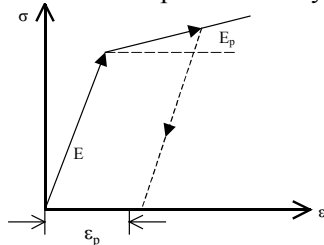

Fig. 13: Perfect Elasto-Plastic behaviour

If the pre-load is close to the yield point once a cyclic external load F_a is applied, the relationship between F_i , F_b , F_c and F_a is as shown in Figure 14. Note the variation in gradient once the yield point is passed. The gradient of the plastic zone of F_b vs F_a curve is;

$$G_{bp} = \frac{k_{bp}}{(k_{bp} + k_c)} < G_b = \frac{k_b}{(k_b + k_c)}$$

Similarly the negative gradient of the F_c vs F_a curve in the plastic zone is;

$$G_{cp} = \frac{k_c}{(k_{bp} + k_c)} > G_c = \frac{k_c}{(k_b + k_c)}$$

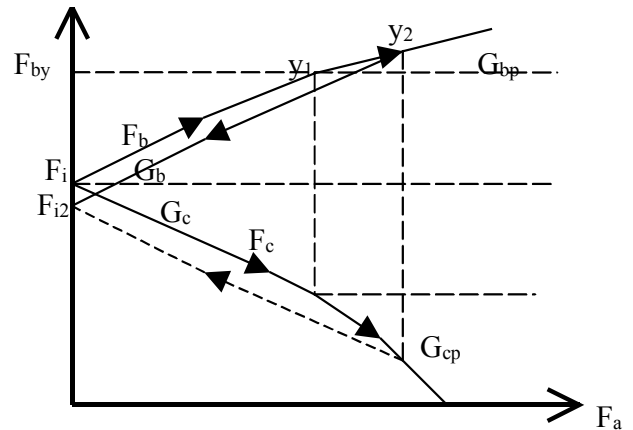

Fig. 14: Bolt tension and clamping force variation crossing yield

Once the applied load F_a is removed the pre-tension in the joint will not reach the original value F_i as shown in the Figure 12. Due to work hardening of the material the new yield point is now moved from Y_1 to Y_2 . In a subsequent loading event unless the applied load exceeds the previously applied maximum load the bolt act as an elastic bolt but with a reduced pre-load (F_{i2}). However, if the load exceeds the previously applied maximum load, then, once the load is removed the pre-load is further reduced.

The load displacement diagram for this case is shown in Figure 15.

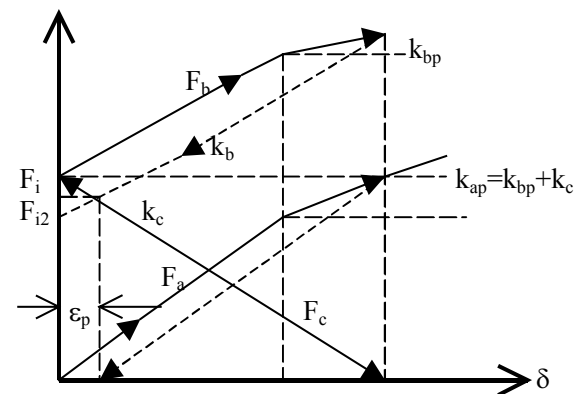

Fig. 15: Load displacement curve beyond yield

8. BOLTING TO YIELD

In some occasions in order to get the highest clamping force the bolts are tightened beyond yield. Especially, when relying on torque to tension the bolt, a better certainty can be achieved when the bolts are tightened beyond the yield, as the effect of variation in torque on the tension is lower. This has to be done carefully, especially with high tensile bolts where the separation between the yield and the failure load is relatively narrow. Furthermore, if a bolt is yielded it shall not be reused, as this will alter the geometry and the mechanical properties of the bolt.

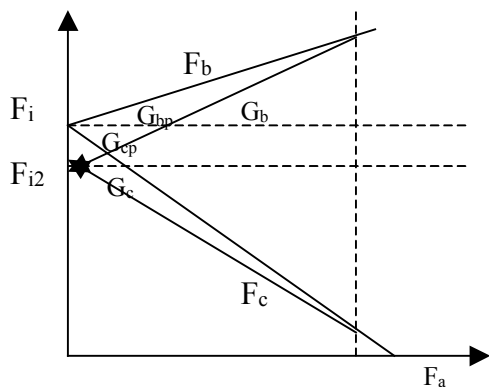

Figure 16: Bolt tension and clamping force variation beyond yield

In the authors opinion this method is suitable for friction grip joints where the joint is loaded in shear and there is no possibility of extra tensile load applied on the bolt.

This method shall not be used to tighten the bolts if there is any uncertainty on whether any additional dynamic or static tensile load will be applied on the joint during its life span.

The relationship between F_i , F_b , F_c and F_a for a joint tightened beyond yield is shown in Figure 16. This is very similar to the Figure 14, without the elastic zone in the bolt tension. When unloading the joint the bolt tension follows a line parallel to the elastic line and end up with a residual plastic displacement which leads to a reduction in pre-tension to F_{i2} . G_{bp} , G_b , G_{cp} and G_c are the gradients as defined earlier.

As k_{bp} is always smaller than k_b G_{bp} will always be smaller than G_b . Similarly, G_{cp} will be larger in magnitude to G_c .

As shown in Figures 16 and 17 if the applied load is increased and then reduced in a joint where the bolts are tightened to yield the bolts will lose pre-load due to plastic deformation. Therefore, tightening to yield is

not suitable for joints where the bolts may be subject to additional tensile loads.

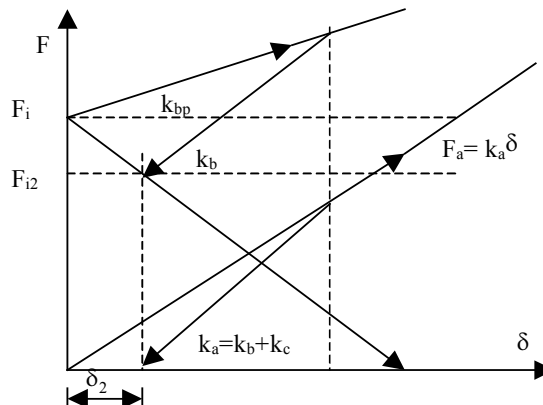

Figure 17: Load displacement curve beyond yield

9. VIBRATION LOOSENING:

It is common experience that some bolts will be loosened when subject to vibrations and dynamic loading. There were several attempts to understand the mechanism of vibration loosening. A large group of researchers believe that the mechanism is somewhat similar to that of vibratory bowl feeders and vibratory conveyors. In general, it is a combination of the inertial forces generated by particular vibration, and friction forces.

Through proper design it is possible to develop mechanical systems where the bolts have a tendency to be tightened under applied loads (eg., some Lawn Mower Bolts, Wheel Nuts). On the other hand, certain situations promote vibration loosening either due to lack of consideration at design level or due to mere complexity of a particular joint. Especially when the joint incorporates soft gasket materials and/or different member materials the complexity increases significantly.

There are several devices available in the market to prevent vibration loosening. Lock nuts, Nylok® Nuts, serrated washers, spring washers, Cottor pins, to name a few. All of these devices provide additional friction force or interlock to the bolt/nut. Depending on the nature of vibrations and other conditions there will be a finite resultant loosening torque that the fastener system has to resist. The said devices help resisting this torque.

The fact that 90% of the applied torque is going to overcome frictional forces, as discussed earlier, may be of value to prevent vibration loosening. The frictional torque is directly proportional to the remaining tensile load on the bolt. Therefore, if the bolts are tightened to a particular pre-load, in such a way that the remaining tension on the bolt under applied load is adequate to generate a friction torque

larger than the loosening torque vibration loosening will not occur. The tests carried out by ATC confirmed that if a typical bolted joint is tightened to a pre-load higher than 65% of the yield load of the fastener vibration loosening will not occur even under severe vibration conditions.

There may be some special occasions where it may not be feasible to apply such pre-loads to the joint. A suitable anti-loosening device may be used in such situations.

10. CONCLUSIONS:

A simple approximate analytical approach is presented. This may help engineers to better understand the performance of bolted joints.

In general, the following specific conclusions are made;

1. The contribution of applied load on the bolt load in a pre-loaded tensile joint depends on the stiffness ratio of the bolt and the joint.
2. Large number of slender bolts is better than a small number of large bolts for a tensile joint subject to dynamic loads.
3. If feasible, longer bolts provide better properties for a dynamic joint than shorter bolts.
4. Correct pre-load (pre-tension) is paramount in achieving high-performance dynamic tensile joints.
5. Calibrated torque wrench is not a reliable method of achieving a desired bolt tension.
6. Common Hydraulic bolt tensioning methods does not adequately account for the relaxation of the joint.
7. LIWs are not suitable for most group-bolted joints. Tightening sequence and process is critical to optimize the use of LIW.
8. Heating the high tensile bolts may result in poor quality joints.
9. Tightening to yield is not suitable for tensile joints.
10. No anti-loosening devices are necessary if the bolts are tightened to at least 65% of the yield load.
11. Most joint failures are due to insufficient pre-load in the bolts.

11. BIBLIOGRAPHY:

Bickford, John H., An Introduction to the Design and Behaviour of Bolted Joints, Marcel Dekker, Inc, New York 1990.

Juinall, Robert C., Fundamentals of Machine Components Design, John Wiley & Sons, New York, 1983.

Ziada, H.H., Abd-El-Latif, A.K., "Areas of contact and pressure distribution in gasketed bolted joints", 1E(1) Journal-ME, Vol 62, November, 1981, pp 77-83.

Finkelston, R.J., Wallace, P.W., "Advances in High-performance mechanical fastening", Paper 800451, SAE, New York, N.Y., Feb 20, 1980.

Fisher, J.W., Struik, J.H.A., Guide to Design Criteria for Bolted and Riveted Joints, John Wiley and Sons, New York, 1974.

Gorenc, B., Tinyou, R., Syam, A., Steel Designers' Handbook, 6th Edition, UNSW Press, 1996

Australian Standard AS4100-1998, Steel Structures.

11. NOMENCLATURE

| | |
|------------|---|
| A_b | - Effective Stress Area of Bolt |
| A_c | - Effective Stress Area of Clamp |
| D | - Diameter of Bolt Shank |
| D_b | - Bearing Diameter of Bolt Head |
| D_h | - Hole Diameter |
| D_j | - Effective Diameter of Joint |
| E | - Young's Modulus of Elasticity |
| E_b | - Young's Modulus of Elasticity Bolt |
| E_c | - - Young's Modulus of Elasticity Clamp |
| F | - Force |
| F_a | - Applied Force |
| F'_a | - Applied Peak Fluctuating Force |
| F_{a0} | - Applied Force to Separate the Clamp |
| F_{a02} | - Applied Force to Separate the Clamp after a plastic cycle |
| F_b | - Bolt Tension Force |
| F'_b | - Peak Fluctuating Bolt Tension Force |
| F_{b0} | - Bolt Tension at Separation of the Clamp |
| F_c | - Clamping Force |
| F_i | - Initial Bolt Tension – Pre-load |
| F_{imax} | - Maximum Pre-Load |
| F_{i2} | - Pre-load remaining after a plastic load cycle |
| F_y | - Yield Load of the Bolt |
| G | - Gradient of Graph F_b, F_c vs F_a |
| K | - Nut Factor |
| K_1 | - Nut Factor due to bolt stretch |
| K_2 | - Nut Factor due to thread friction |
| K_3 | - Nut Factor due to Under head/nut Friction |
| k | - Stiffness |
| k_a | - Joint Stiffness |
| k_b | - Bolt Stiffness |
| k_c | - Clamp Stiffness |
| L | - Length |
| L_b | - Effective Bolt Length |
| L_c | - Effective Clamp Length |
| L_g | - Joint Grip Length |
| p | - Thread Pitch |
| r | - Radius |
| rt | - Thread Effective Radius |
| rb | - Under Head/Nut Effective Radius |
| S'_a | - Peak Fluctuating Stress |
| S_m | - Mean Stress |
| S_u | - Ultimate Tensile Stress (UTS) |
| S_y | - Yield Stress (YS) |
| T | - Torque |

Greek Symbols;

| | |
|----------------|-------------------------------|
| $\delta\theta$ | - Infinitesimal Bolt Rotation |
| δ | - Elongation |

- Δ - Variation
- μ - Friction Coefficient
- μ_b - Under Head/Nut Friction Coefficient
- μ_t - Thread Friction Coefficient
- α - Flank Angle of the Thread

Indices:

- p - Plastic State
- b - Bolt
- c - Clamp
- i - Initial